

1.

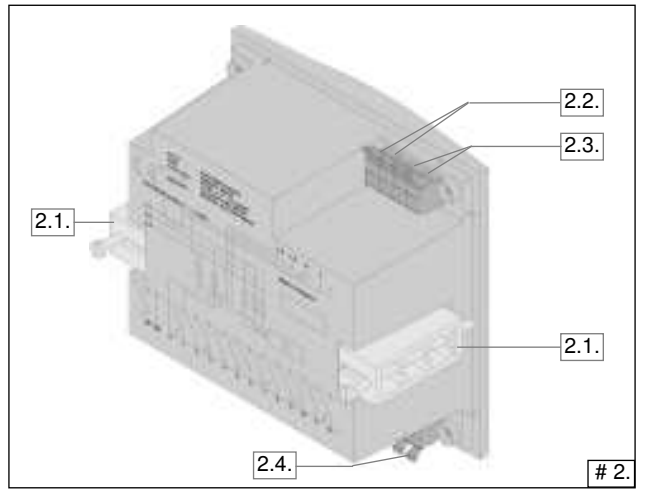

2.

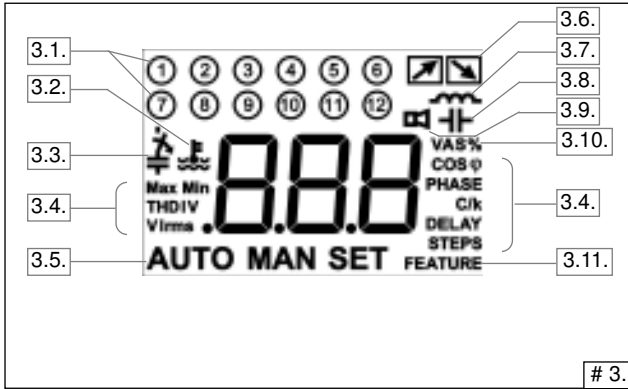

3.

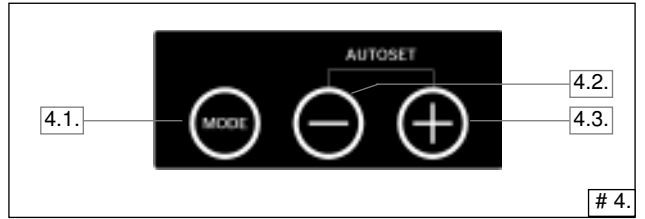

4.

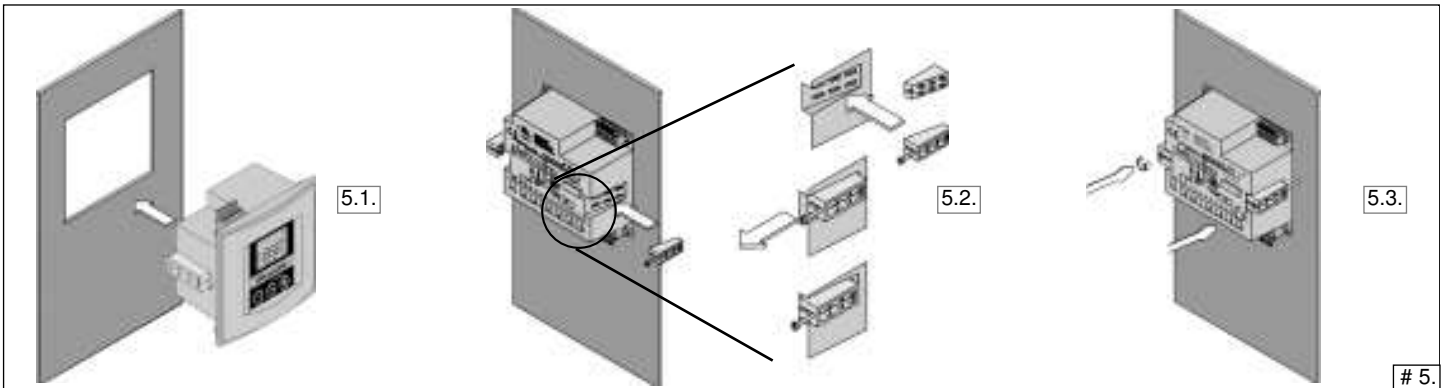

5.

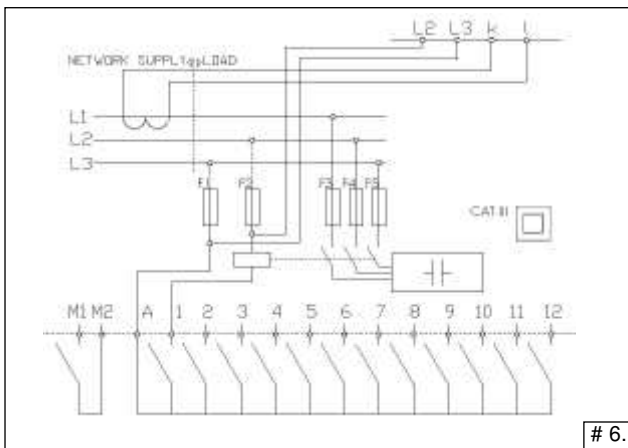

6.

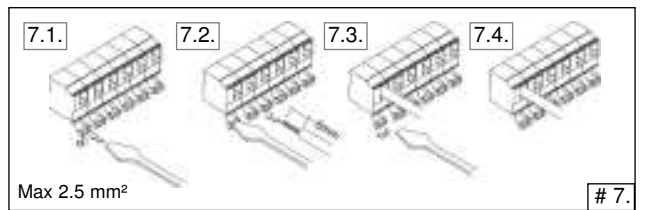

7.

$$\text{3-Phase } C/k = \frac{2}{3} \times \frac{Q \times 1000}{\sqrt{3} \times U \times k}$$

$$\text{1-Phase } C/k = \frac{2}{3} \times \frac{Q \times 1000}{U \times k}$$

C/k: 3-Ph/400V

CT Ratio	k	Capacitor step rating (kvar)															
		5	10	15	20	30	40	50	60	70	90	100	120				
10/1	50/5	10	.447	.895	1.34	1.79	2.68										
20/1	100/5	20	.224	.447	.671	.895	1.34	1.79	2.24	2.68							
30/1	150/5	30	.149	.298	.447	.597	.895	1.19	1.49	1.79	2.09	2.68	2.98				
40/1	200/5	40	.112	.224	.336	.447	.671	.895	1.12	1.34	1.57	2.01	2.24	2.68			
60/1	300/5	60	.075	.149	.224	.298	.447	.597	.746	.895	1.04	1.34	1.49	1.79			
80/1	400/5	80	.056	.112	.168	.224	.336	.447	.559	.671	.783	1.01	1.12	1.34			
100/1	500/5	100	.045	.089	.134	.179	.268	.358	.447	.537	.626	.805	.895	1.07			
120/1	600/5	120	.037	.075	.112	.149	.224	.298	.373	.447	.522	.671	.746	.895			
160/1	800/5	160	.028	.056	.084	.112	.168	.224	.280	.336	.392	.503	.559	.671			
200/1	1000/5	200	.022	.045	.067	.089	.134	.179	.224	.268	.313	.403	.447	.537			
300/1	1500/5	300	.015	.030	.045	.060	.089	.119	.149	.179	.209	.268	.298	.358			
400/1	2000/5	400	.011	.022	.034	.045	.067	.089	.112	.134	.157	.201	.224	.268			
600/1	3000/5	600		.015	.022	.030	.045	.060	.075	.089	.104	.134	.149	.179			

9.

Linear		Circular	
CT	CS	CT	CS
1	1	1	1
2	1	1	1
3	1	1	1
4	1	1	1
5	1	1	1
6	1	1	1
7	1	1	1
8	1	1	1
9	1	1	1
10	1	1	1
11	1	1	1
12	1	1	1

8.

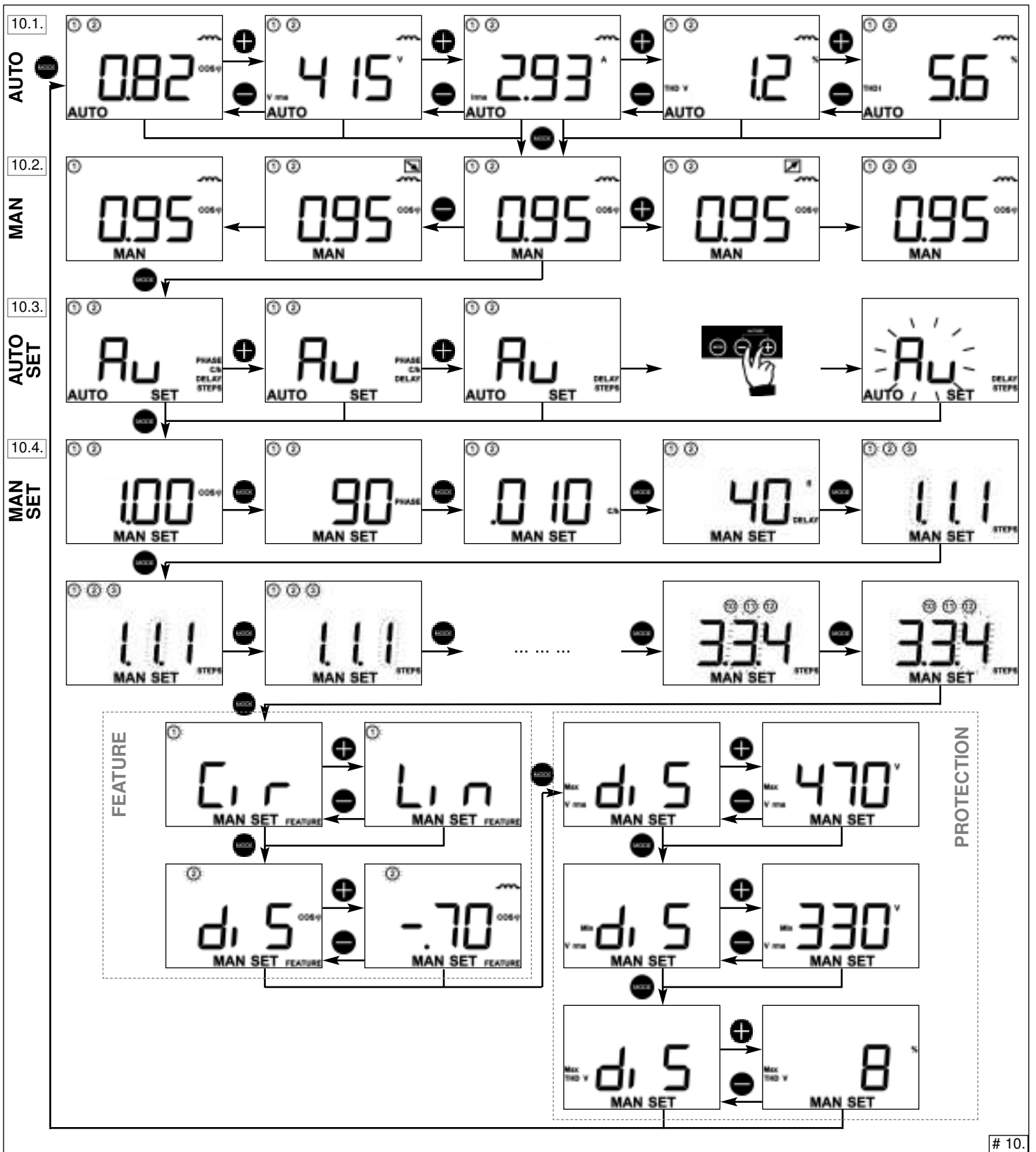

10.

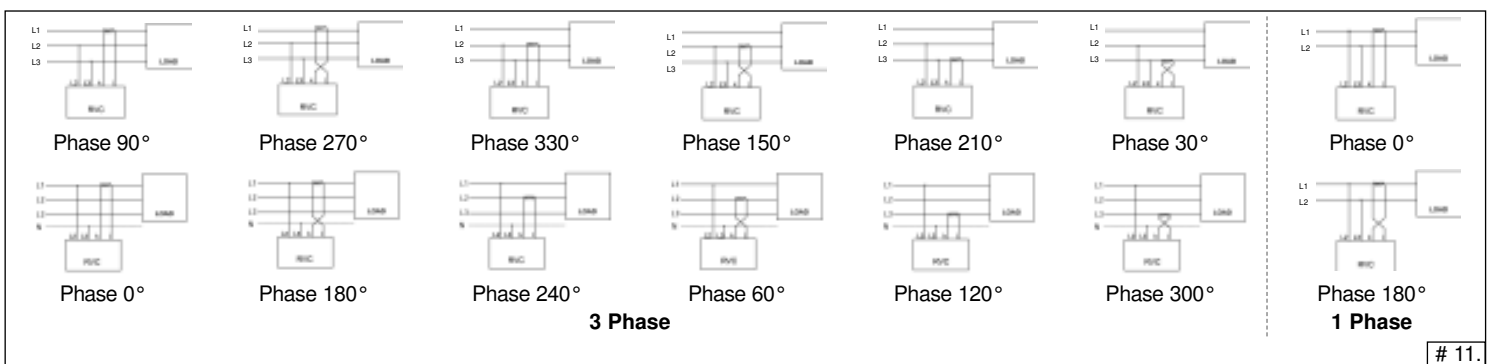

11.